

Myers[®]
INDUSTRIAL PRODUCTS

E Series

Reciprocating Pump (Shaft Drive) Safety Instructions and Service Manual

E54-30	Part No. 26866F000
E54-30L	Part No. 26866F010
E70-23V	Part No. 26866F100
E70-23VL	Part No. 26866F110
E80-20V	Part No. 26866F300
E80-20VL	Part No. 26866F310
E80-25	Part No. 26866F104
E110-14	Part No. 26866F200
E110-14L	Part No. 26866F210

Table of Contents

SPECIFICATIONS	3
DIMENSIONS	4
BELT DRIVE (Dimensions)	4
STARTING THE PUMP	4
SUGGESTED MAINTENANCE SCHEDULE	5
LUBRICATION.....	5
ADDITIVES FOR CRANKCASE OIL.....	5
SERVICING THE PUMP:	
REMOVING PISTON	5
INSTALLING THE PACKING	6
REMOVING THE CYLINDERS.....	6
CYLINDER INSTALLATION.....	6
REMOVING THE SEATS: Wing Guided Valves	6
REPLACEMENT OF VALVES.....	7
REPLACING PISTON ROD SEALS	7
REMOVING CRANKSHAFT AND PINION SHAFT	7
REPLACING PINION SHAFT & SHIMMING BEARINGS.....	8
REPLACING CRANKSHAFT & SHIMMING BEARINGS	8
RECONDITIONED CRANKSHAFTS	9
SERVICING CONNECTING LINKS.....	9
CROSSHEAD AND PISTON RODS.....	9
RECOMMENDED TORQUE (Foot-pounds).....	9
VALVE LIFTERS	10
SERVICE CHART & TROUBLESHOOTING	11
CROSS-SECTIONAL VIEWS OF PUMPS:	
SIDE VIEW – PRE JUNE 1, 2008 E70-23, E80-20.....	14
SIDE VIEW – POST JUNE 1, 2008 E70-23V, E80-20V, E80-25	15
POWER-END	16
PARTS LIST	17

SPECIFICATIONS

	TRIPLEX PUMP MODELS				
	E54-30	E70-23V	E80-20V	E80-25	E110-14
RATED MAX CAPACITY (GPM)	54	70	80	80	110
PINION SHAFT RPM @ MAX. CAPACITY	1823	1807	1828	1828	1817
PRESSURE RATING (PSI)	3000	2300	2000	2500	1400
CYLINDER BORE DIA. (INCHES)	1.750	2.000	2.125	2.125	2.500
PISTON STROKE LENGTH (INCHES)	3.75				
GEAR REDUCTION RATIO	3.95 to 1				
TEMPERATURE RATING, MAX.	160°F				
SUCTION SIZE (INCHES) NOMINAL	3 NPT				
DISCHARGE SIZE (INCHES) NOMINAL	1-1/4 NPT				
INPUT SHAFT DIAMETER (INCHES)	1.6250/1.6245				
KEYWAY (INCHES)	3/8 X 3/16				
WEIGHT (Lbs.)	525				
FLUID-END CASTING MATERIAL	DUCTILE IRON				
VALVE MATERIAL	17-4 PH with POLYURETHANE INSERT				
VALVE SPRING MATERIAL	STAINLESS STEEL				
CYLINDER MATERIAL	STAINLESS STEEL/CERAMIC OXIDE COATING				

E-54-30

GPM LPM	RPM	Horsepower/Kilowatts Required For:				
		1800 PSI 124 BAR	2100 PSI 145 BAR	2400 PSI 165 BAR	2700 PSI 186 BAR	3000 PSI 207 BAR
30 113	1012	37 28	43 32	49 36	55 41	62 46
36 136	1215	44 33	52 39	59 44	66 49	74 55
42 158	1417	51 38	60 45	59 51	79 59	86 64
48 181	1620	59 44	69 51	79 59	89 66	98 73
54 204	1823	66 49	79 59	89 66	100 75	111 83

E70-23V

GPM LPM	RPM	Horsepower/Kilowatts Required For:				
		1900 PSI 131 BAR	2000 PSI 138 BAR	2100 PSI 145 BAR	2200 PSI 152 BAR	2300 PSI 159 BAR
30 113	914	39 29	41 31	43 32	45 34	47 35
40 151	1143	52 39	55 41	57 42	60 45	63 47
50 189	1371	65 48	69 51	72 54	75 56	80 60
60 227	1600	78 58	82 61	86 64	90 67	95 71
70 265	1828	91 68	96 72	100 75	105 78	110 82

E80-20V / E80-25

GPM LPM	RPM	Horsepower/Kilowatts Required For:							
		1200 PSI 83 BAR	1400 PSI 97 BAR	1600 PSI 110 BAR	1800 PSI 124 BAR	2000 PSI 138 BAR	2200 PSI 152 BAR	2400 PSI 165 BAR	2500 PSI 172 BAR
40 151	914	33 25	38 29	44 33	49 37	55 41	60 45	66 49	69 51
50 189	1143	41 31	48 36	55 41	62 46	69 51	75 56	82 61	86 64
60 227	1371	49 37	58 43	66 49	74 55	82 61	91 68	99 74	103 77
70 265	1600	58 43	67 50	77 57	86 64	96 72	106 79	115 86	120 90
80 30	1828	66 49	77 57	88 66	99 74	110 82	121 90	132 98	137 102

E110-14

GPM LPM	RPM	Horsepower/Kilowatts Required For:			
		800 PSI 55 BAR	1000 PSI 69 BAR	1200 PSI 83 BAR	1400 PSI 97 BAR
70 265	1157	38 28	48 36	58 43	67 50
80 302	1322	44 33	55 41	66 49	77 57
90 340	1487	49 37	62 46	74 55	86 64
100 378	1652	55 41	69 51	82 61	96 72
110 416	1817	60 45	75 56	90 67	106 79

NOTE: Flow (GPM/LPM) based on 100% volumetric efficiency. Horsepower and kilowatts required are based on 85% overall efficiency.

Horsepower requirements are at Myers pump input shaft. The efficiency of the hydraulic pump, hydraulic motor, etc. must be considered to determine horsepower required to drive complete system.

GENERAL INSTRUCTIONS

CAUTION: Positive Displacement Pumps must have a proper size and operable type of pressure regulating valve or pressure relief valve piped into the discharge line. This is mandatory to prevent damage to pump and piping or possible injury to personnel. **DO NOT** install any valves or shut-off devices in the bypass line from pressure regulator to tank or supply.

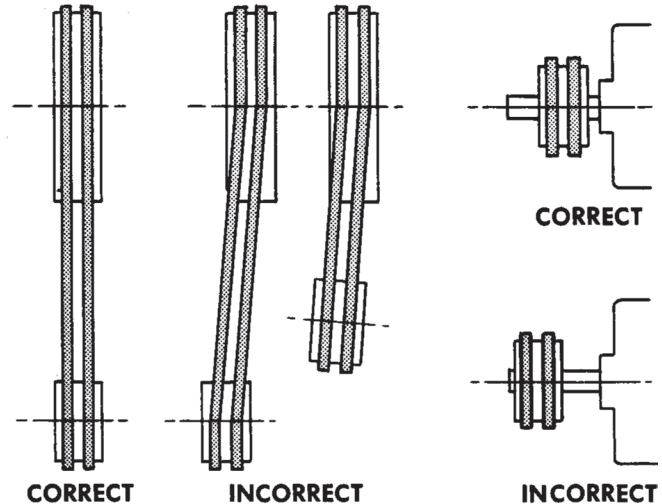

DIMENSIONS

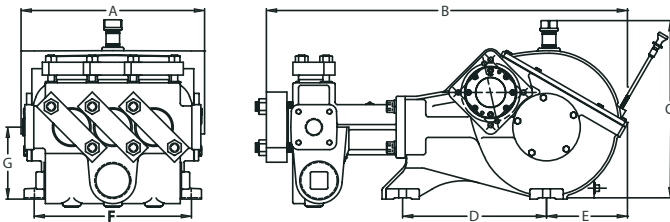

Weight Lbs. (Kg)	Dimensions in Inches (Millimeters)							Diameter of Mounting Hole
	A	B	C	D	E	F	G	
525	21	36.25	17	14	7.5	16	10.38	0.75
238	533.4	920.75	431.8	355.6	190.5	406.4	263.7	19.05

BELT DRIVE SEWER CLEANERS

With belt drives, pulley on both engine and pump should be located as closely as possible to bearing to reduce bearing and shaft bending loads. Make sure that all bolts, nuts, set screws, and keys are properly tightened.

PULLEY LOCATION ON PUMP AND MOTOR SHAFT

STARTING PUMP

A. Before Starting:

1. Read all instructions carefully.
2. Fill pump crankcase with recommended oil to level mark on oil sander. Oil recommendations are covered in lubrication section of pump instructions.
3. Replace all drain plugs in pump and piping.
4. Inspect tank to be sure that no foreign material is in tank or suction line.
5. Fill tank at least half full or connect suction to water supply. Open valve (if present) in suction line. **Avoid prolonged dry operation which may cause excessive wear on cylinders and piston packing. Be sure that an operating pressure gauge is located in discharge line.**
6. Make sure all valves, including spray gun or nozzles, are open in discharge line. Spray gun may be anchored to discharge back into tank.
7. Completely back off pressure adjusting screw on pressure regulating valve.

B. Starting the Unit:

1. After starting, close discharge valve or spray gun slowly while watching pressure gauge to make sure relief valve or unloader is operating properly.
2. Adjust relief valve or unloader to desired pressure. See regulator instructions.
3. Cycle nozzles or gun on and off to be sure that pressure adjustment and regulator operation is satisfactory.

NOTE: Nozzle capacity should not exceed 90% of pump capacity for satisfactory regulator operation. **AVOID FREEZING** by draining all water from pump and system in cold weather.

SUGGESTED MAINTENANCE SCHEDULE

OPERATION	INTERVAL
Check oil level	Daily
Drain and change oil	300 hr. (1)
Replace piston packing	500 hr. (2)
Inspect valves and springs	500 hr. (3)
Inspect connecting link bearing inserts	1000 hr. (4)
Inspect crankshaft tapered roller bearings	2000 hr.

- (1) Drain at operating temperature to prevent contamination from setting.
- (2) Inspect frequently for leakage; replace before 500 hours if any cylinder exceeds 10 drops per minute leakage. Packing may not look badly worn but will often be shiny and hard and won't seal well.
- (3) Replace if cracks and heavy wear are present.
- (4) Replace at first signs of fatigue or wear to prevent damage to crankshaft.

LUBRICATION

Fill gear case with Mobilgear 630 or equivalent 80W90 oil to capacity listed in chart. Note oil level on oil dipstick, and maintain at this level.

NOTE: Slow speed operation of Myers Reciprocating Pumps can be accomplished by adding additional oil to the crankcase (see chart). The higher level compensates for lack of splash lubrication at slow speeds.

Some slight leakage may occur around crossheads and dipstick/vent area with additional oil.

For further information, please consult the factory.

IMPORTANT: After first 30 hours of operation drain oil from gear case (preferably drain at operating temperature), replace plug and refill crankcase with new oil as above. Change oil every 300 hours thereafter. Check oil level daily and add oil as needed.

ADDITIVES FOR CRANKCASE OIL

Use of Molybdenum Disulfide (MoS₂) is optional as an additive to the petroleum-based gear case oil in back geared pumps and speed reducers manufactured by Myers. Do not use this additive with synthetic oil. It appears to be so effective in reducing wear and friction that power train life may be doubled between overhauls.

Volume of liquid MoS₂ concentrate required at various speeds

PINION RPM RANGE	GEAR CASE CAPACITY	VOLUME MoS ₂ CONCENTRATE OR DISPERSION "M" FOR	
		5%	10%
1600 - 1800	6½ Qts.	7 Fl. Oz.	14 Fl. Oz.
1000 - 1599	6½ Qts.	9 Fl. Oz.	18 Fl. Oz.
600 - 999	6½ Qts.	10 Fl. Oz.	20 Fl. Oz.

The MoS₂ fluid concentrate is marketed by Dow Corning, Phone (517)-496-6000 or www.molykote.com/iam under the designation "Molykote M Gear Guard." Several other brands are available. Follow instructions of manufacturer.

SERVICE

CAUTION: Disengage clutch, disconnect electrical leads to motor, or remove spark plug leads on engine. Following work on any internal pump parts, it is important to tighten all clamps, caps and assemblies to specific torque ratings. Refer to Recommended Torque chart.

CAUTION: Also inspect cylinders for linear grooving by running your thumbnail circumferentially around bore of cylinder. If any grooving is detected also replace cylinders. New packing will rapidly cut or wear out in grooved cylinders.

SERVICE

CAUTION: Disengage clutch, disconnect electrical leads to motor, or remove spark plug leads on engine. Following work on any internal pump parts it is important to tighten all clamps, caps and assemblies to specific torque ratings. Refer to Recommended Torque chart.

REMOVING PACKING

Move assembly to front end of cylinder (top dead center). Remove valve assembly if required to provide clearance. Remove cap screw with an Allen wrench (Allen wrench, Part No. 8574A11). Retract piston rod and insert tool as shown. Pull packing assembly out or push by rotating crankshaft by hand.

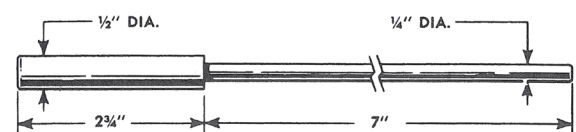
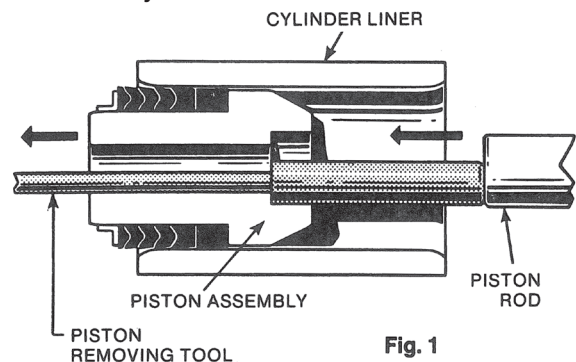

Fig. 2 Suggested tool for removing V-Ring plunger assembly.

CAUTION: Also inspect cylinders for linear grooving by running your thumbnail circumferentially around bore of cylinder. If any grooving is detected also replace cylinders. New packing will rapidly cut or wear out in grooved cylinders.

INSTALLING PACKING

Assemble V-Rings onto stud as shown. Lubricate the outside of the assembly with Molykote or other grease for ease in insertion — do not use a graphite type grease. When installing each V-Ring assembly, rotate crankshaft until piston rod is at forward position. Place copper gasket 5030A128 in position in stud using a small amount of Permatex to hold in place. **NOTE:** Apply Loctite RC35 to capscrew prior to piston installation. Follow instructions on label and make certain threads in piston rod are clean and free of any grease or oil. Assemble capscrew, etc., into piston assembly and push into cylinder. Torque the capscrew to 50 ft. lb. using a hexagonal socket attachment 3/8" across flats.

REMOVING CYLINDERS (Fig. 5)

1. First remove packing as outlined previously.
2. Rotate crankshaft until piston rod is in rear position.
3. Insert puller (3) through inside of cylinder and pilot over piston rod.
4. Insert disc (4) into slots on puller (3).
5. Slip plate (2) over threads on puller (3) as shown.
6. Screw nut (1) on thread on puller (3) and snug up.
7. Tighten nut (1) until liner breaks loose.
8. Loosen nut (1) and slip disc (4) out of slots.
9. Remove puller (3) and repeat to remove other cylinders.

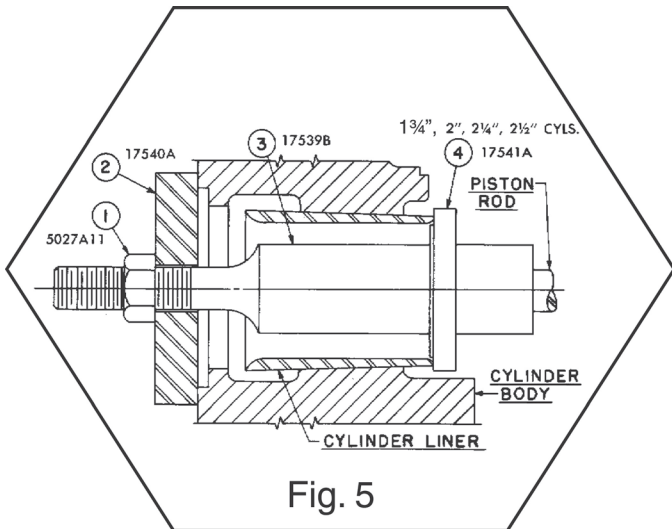

Fig. 5

CYLINDER INSTALLATION

Reasonable care and judgment should be used when installing the new cylinder. Clean out any accumulation of loose rust or corrosion in cylinder body. Install a new O-ring in groove on tapered portion of cylinder, lubricate O-ring with oil or grease for ease in insertion. Position cylinder carefully by hand to avoid cutting the O-ring. Drive into position firmly with a wooden block and mallet. Never use a hydraulic press; excessive force can cause damage and make cylinders very difficult to remove for later replacement.

REMOVING SEATS: Wing Guided Valves

- A. First remove valve caps (61) and cylinder caps (72) which provide access to suction and discharge valves. Remove the stainless steel cage which serves as a valve guide and spring retainer. Remove cage (65), spring (66), and valve (67), from the pump fluid end. (Fig. 6)

Suction valve seats are removed as above except two stud lengths are joined using coupling.

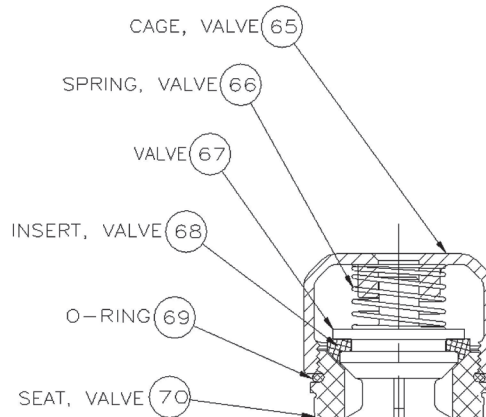

Fig. 6

SUCTION & DISCHARGE VALVE ASSEMBLY Part No. (TS18-AR0-AC0714)

REPLACEMENT OF VALVES

- A. Inspect tapered valve seat bore in fluid end for rust and wipe out excess with a rag. Place a new lower seat in tapered hole. With a hardwood round dowel, drive lower seat firmly into place with a hammer. Repeat for upper seat being sure to also inspect the tapered bore in housing for rust.

IMPORTANT: Both the valve seat O.D. and tapered bore I.D. MUST BE VERY CLEAN.

- B. Reassemble valve, spring, and cage as shown in Fig. 6. Be sure that springs are in correct location. When upper and lower valve seats are the same size, the heavier spring (larger diameter wire) is always installed on upper or discharge valve.

NOTE: Be sure that cage is tightened onto valve seat.

- C. Inspect seals on valve and cylinder caps. Replace if seals show signs of wear or "nibbling." Lubricate seals and replace cap, bar and nuts. Torque cap covers nuts to specification shown in torque chart.

CAUTION: Do not use a hand or arbor press to install valve seats. It is possible to crack cylinder body with excessive pressure.

REPLACING PISTON ROD SEALS

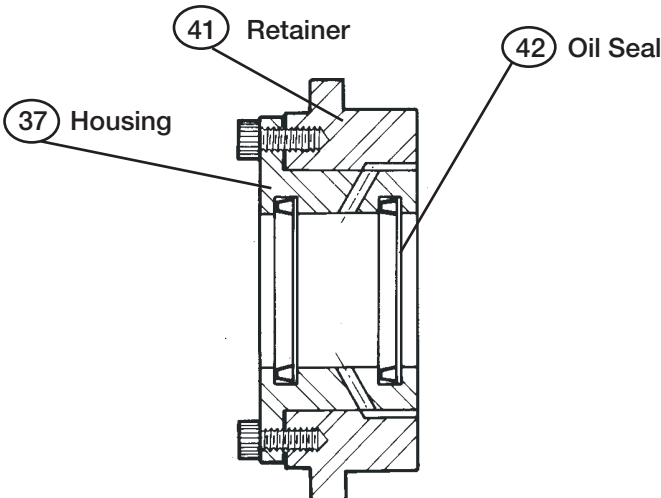

Fig. 8

The rod seal assembly contains two seals, two oil seals with lips facing power end. The oil seal can be replaced without taking the fluid end off by removing the cylinder and piston to allow access for oil seal housing. Unscrew two Allen screws and place into the other two tapped holes. Gradually screw them in to push oil seal housing off the retainer. After assembling new seals in oil seal housing an assembly thimble should be used on end of crosshead rod for sliding oil seal housing back into retainer. Check gasket, replace if damaged.

An assembly thimble should be used on small end of the piston rod to expand sealing edge as it is pushed on. Figure 9 illustrates an assembly thimble being placed on the end of the rod. Figure 10 shows a recommended thimble for installation of oil seals. The thimble should be machined from high carbon steel and polished on the exterior to reduce possibility of seal lip damage.

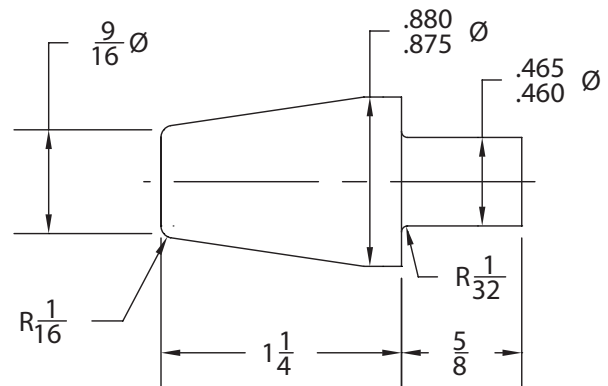
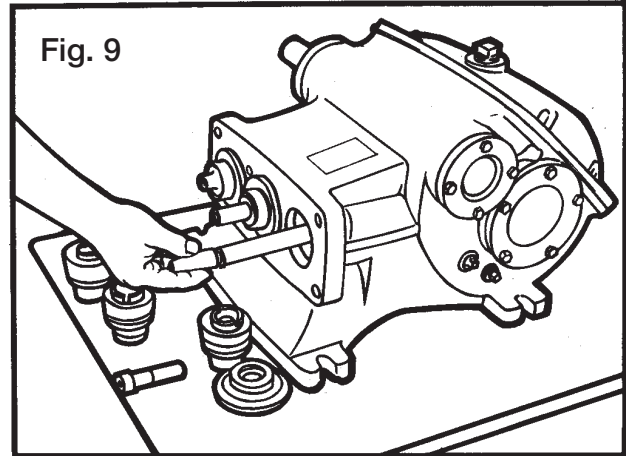

Fig. 10

REMOVING CRANKSHAFT AND PINION SHAFT

Remove piston assemblies. Remove connecting link caps and move the link-crosshead assembly as far forward as possible.

IMPORTANT: Note the markings on the connecting links and caps; these parts are not interchangeable and must be reassembled in their original positions.

Wedge a 3/4" board between crankshaft gear and gear case so that crankshaft will be held in place against pinion shaft. Remove both crankshaft bearing caps (see Fig. 11). Hold crankshaft at ring gear and left-hand link journal (to prevent dropping into bearing bores), remove from gear case by moving crankshaft to right until left end can be swung free.

To remove pinion shaft, remove bearing cap bolts.

Next, using a lead or rawhide hammer, tap the end of pinion shaft extension to remove bearing cup at opposite end. After removing pinion shaft, the remaining bearing cup can be removed by gently tapping against the peripheral edge of the cup with a brass rod.



Fig. 11

REPLACING PINION SHAFT AND SHIMMING BEARINGS

After installing the link-crosshead assemblies and moving them toward the fluid end as far as possible, tap right-hand pinion shaft bearing cup into position using the bearing cap. Make sure that the spacer is properly seated on drive end of pinion shaft (the curve side should match the fillet radius of pinion shaft). Place pinion shaft in position and tap left-hand bearing cup into place.

- A. Cover shaft keyway with vinyl tape to protect lip of oil seal, slide on the open bearing cap to which has been added approximately .030 shim, tighten the four cap screws to recommended torque.
- B. Put on other cap using total shim thickness known to be more than needed so that resulting end play is greater than required. Tighten cap screws holding pinion or crankshaft caps to gear case. Rotate pinion shaft back and forth and apply about 15 lbs. axial force to properly seat tapered rollers. Measure end play by using an indicating gage in a manner shown in Fig. 12.
- C. Subtract recommended end play (.005–.009) from actual end play as found above. This is the amount of shim that must be removed. After excess shim thickness has been removed, replace caps and retighten cap screws. Again measure end play. If end play is not within limits recommended, add or subtract shims as required.

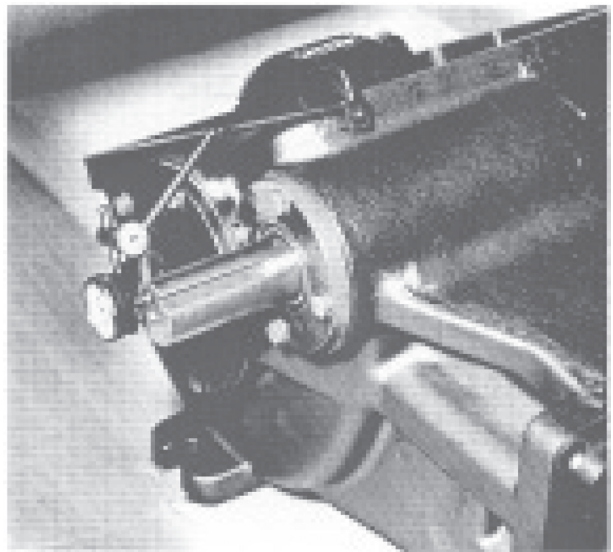

Fig. 12

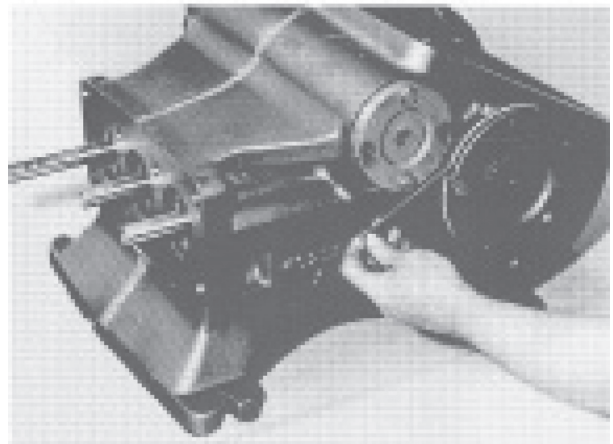

Fig. 13

Good performance of tapered roller bearings on a shaft requires that correct shaft end play first be made by shimming. This ensures that uneven heating, as encountered during warm-up, will not overload the bearings, and that after all parts are heated to approximately the same temperature the resulting end play will be correct. Shouldered roller bearings also require correct shimming to ensure that the shoulder will properly locate the shaft and yet not bind.

REPLACING CRANKSHAFT AND SHIMMING BEARINGS

Press the bearing cups into the caps. Place one cap into position on the right side with cap screws engaged about one turn; install crankshaft (left end first), then push both bearing caps into place. Extreme care should be exercised to avoid damage to gear teeth, bearings, and link journals.

For quiet operation and long life, the crankshaft and bearings must be installed with .003 to .005 in preload; the following procedure will provide an accurate adjustment. Before starting, loosen the four cap screws on the pinion shaft bearing cap.

- A. Place about .045 shim on the right crankshaft bearing cap, tighten the five cap screws.
- B. Install the left cap without shims; secure with two cap screws positioned exactly as shown in Fig.13. Torque the two cap screws at 13 foot pounds, rotate the crankshaft, retorquing the cap screws. Do this three times to properly seat the tapered roller bearings.
- C. Measure (adjacent to the cap screws) the shim gap remaining between the bearing cap and the gear case.
- D. The required shim thickness for this cap is equal to the average gap measurement plus .022".
- E. Insert correct shim thickness under left bearing cap and tighten cap screws.
- F. Install connecting links and caps; note the markings; torque cap screws to 40 ft. lb.
- G. **IMPORTANT** – Check for adequate side clearance of links on crankshaft. Some shims must be moved from one end of the crankshaft to the other until sideways movement of all links can be seen.
- H. Check torque of cap screws on all bearing caps.

RECONDITIONED CRANKSHAFTS

When the crank throws are only slightly damaged, such as small surface grooves cut part way around the bearing surface, they can sometimes be reconditioned for further use. This can be done by sandpapering and polishing until all ridges are completely removed. The final polishing operation should be with very fine emery cloth. If the surface is badly damaged, the crankshaft can often be salvaged by “metalizing” the crank throw and then regrinding and polishing to the original diameter of 3.1240–3.1245".

SERVICING CONNECTING LINKS

The connecting rod link is furnished with replaceable split sleeve bearing inserts at the crank throw. It is never practical to attempt to refit connecting links to the crankshaft bearings by filing or grinding the mating faces of the link cap where it contacts the link. Always be sure that the proper side of the link is placed upward when attaching it to the crankshaft. The upper side contains an oil hole at the crosshead end of the link. This oil hole must be up to allow proper oil feeding to the crosshead pin bushing. The wrist pin is press-fitted into crosshead and slip-fitted through the bronze bushing. Use arbor press instead of hammering the wrist pin to force it in. Check to see if link is free to rotate after the wrist pin is

pressed in. Make sure that neither side of wrist pin does NOT protrude beyond the crosshead.

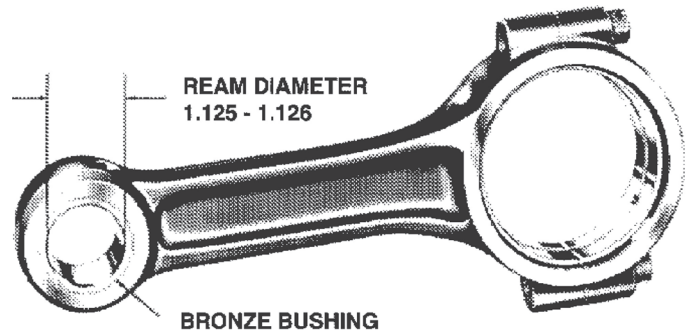

Fig. 14

The crosshead end of the connecting link is fitted with a bronze bushing. When new replacement links are obtained, these bushings are reamed to the proper size for immediate installation. If the bushing only is replaced, it may be necessary to ream the new bushing to the proper inside diameter after it is pressed into the link. When placing the bushing on the link be sure that the oil holes in the bushing and link will be in line after the bushing is pressed into position. Figure 14 shows the proper diameter to which the bushing must be reamed for proper seating of the crosshead pin. Note that the ream diameter must be parallel to the I.D. of the sleeve bearings within 0.001" T.I.R.

CROSSHEAD AND PISTON RODS

Repair parts for the crosshead and piston rod are supplied only as a complete unit. If either of these parts becomes worn it is necessary to replace both the crosshead and piston rod. Under normal conditions a crosshead will not wear nor will the bore of the crankcase wear to the extent that oversize crossheads will be required. If extreme wear does occur, it will be due to severe damage from the lack of oil or a fairly large metal object scoring the crosshead bore. A clearance of .002" to .004" is standard for the crosshead. The parts can wear until considerably more clearance than this exists before harmful operation will occur.

RECOMMENDED TORQUE (Foot-pounds)	
FASTENER LOCATION	
Link Bearing Caps	40
Crankshaft End Caps	20
Pinion Bearing End Caps	20
Cap Screw, 3/4 (Fluid End to Power End)	250
Cap Screw, 5/8 (Fluid End to Power End)	150
Cylinder Cap Clamps (Front)	200
Valve Cap Clamps (Top)	100

VALVE LIFTERS

Optional valve lifter assemblies are available, Part No. 13014A004K; three are required per pump. The purpose of these is to lift the inlet valve guide to allow liquid to drain from the cylinder chamber. This will prevent damage to the pump as a result of freezing of the pumped liquid.

To operate, one of the 3" NPT pipe plugs in the inlet chamber should be removed. Then the knob of the lifter is turned to cause upward movement of the lifter stem that contacts and raises the valve guide. Liquid will then drain from the cylinder chamber, into the inlet chamber and then out of the pump.

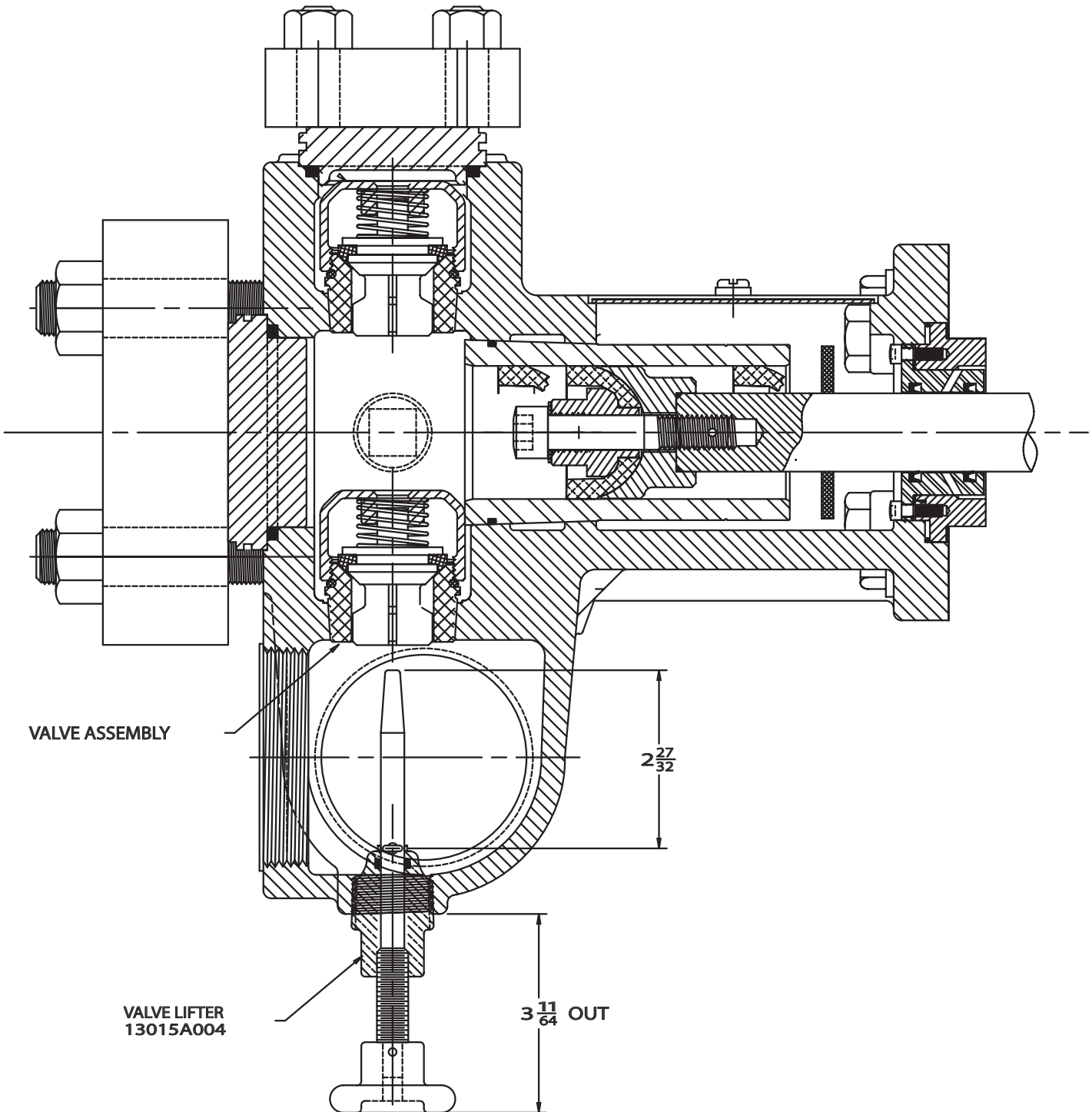

"E" PUMP SERIES
WITH VALVE LIFTERS

WARNING: THIS PUMP MUST BE INSTALLED WITH A PRESSURE RELIEF VALVE IN DISCHARGE LINE

SERVICE CHART

SERVICE PROBLEM

A. Failure of pump to build pressure with discharge closed					
B. Failure to hold pressure with discharge open					
C. Pump is noisy					
D. Pump gets hot					
E. Pressure gauge shows abnormal fluctuation					
POSSIBLE CAUSE OF PROBLEM	E	D	C	B	A
1. Pump not primed					X
2. Valve closed in suction line			X		X
3. Suction line or sediment chamber clogged			X	X	X
4. Air leak in suction line			X	X	X
5. Pressure regulator valve badly worn or not properly adjusted				X	X
6. Broken valves or springs	X		X	X	
7. Pump packing or valves badly worn	X		X	X	
8. Pressure regulator bypassed by open #1 valve				X	X
9. Pump cylinder body cracked			X	X	X
10. Water in crankcase		X			
11. Worn connecting link inserts or wrist pin bushings		X	X		
12. Lack of oil in crankcase		X	X		
13. Foaming mixture in tank	X		X	X	
14. Regulator plunger sticking	X				
15. Foreign matter under pump valve	X		X	X	
16. Loose plunger rod			X		
17. Improper preload of crankshaft bearings		X	X		

Explanation of the Service Chart

1. Pump priming is usually not necessary when the pump is installed correctly. However, there are certain unusual conditions which may make it necessary to prime the pump to get the pumping action started. Priming will be required under conditions where it is impossible for the piston to displace the air in the pump and replace it with water. This could be caused by a high suction lift (high from the water supply to the pump), the valves being stuck on the seat, such as after pumping a sticky fluid, or it might be caused by valves sticking due to extreme corrosion of the valves and seats. A pump will not prime readily if someone has tampered with the valve springs causing them to exert undue pressure of the valve plates against the valve seats. When the pump appears to need priming this condition can be checked by pouring water into the cylinder body through one of the valve cap openings or into the pump discharge opening at the same time operating the pump to work the water into the cylinder and valve passages.
2. Frequently a gate valve is installed in the suction line between a tank or pressure line and pump sediment chamber. This valve is usually installed in the line to shut off the supply source for cleaning sediment chamber or for pump repairs.

If this valve is closed or even partially closed it will interfere with the flow of water to the pump suction to such an extent that the pump will not perform to full capacity. If the valve is partially closed it may cause severe knocking and vibration of the pump because the water cannot flow into the cylinder cavities fast enough.
3. A sediment chamber should be installed in the suction line between the gate valve and the pump suction. The strainers in these sediment chambers are of more than adequate capacity to allow a free flow of the liquid to the pump. However, because of its normal function of collecting sediment the strainer may become severely clogged and in some cases, it will completely stop the flow of liquid to the pump. The length of time the pump may operate before it is necessary to clean the strainer will depend upon the type of liquid pumped. After the pump has been used a short period the operator will soon become familiar with the amount of running time between strainer cleanings.

4. Any piston pump when operated at high pressure will not operate satisfactorily or quietly if a mixture of air and water is allowed to enter the pump suction. For this reason, a small air leak in the suction line will cause the pump to knock and vibrate excessively. This holds true only for a small air leak which allows the pump to draw a certain amount of water mixed with air on each stroke of the piston. A large air leak will cause the pump to lose prime after which it cannot be reprimed until the air leak is stopped. Air leaks may occur at the joints of the suction line piping, at the gate valve in the suction line, at the gasket sealing the cap on the sediment chamber or by a crack in the suction wall of the cylinder body, such as might be caused by freezing if the pump is not properly drained in freezing weather. There is also a definite possibility of air drawing past the packing on the suction stroke if the packing is badly worn.
5. If the pressure regulator internal bypass valve is badly worn it will allow too much of the pump capacity to be bypassed and recirculated back to the tank. By examining the flow from this valve with the discharge turned on, it can be determined whether or not the valve is worn. If a heavy flow continues when the discharge is turned on, it is usually a good indication that the valve is badly worn and should be replaced or that something is lodged under the valve holding it open.
6. A broken pump valve or spring will often prevent one cylinder from functioning properly. Very rough pulsing discharge, a knocking sound, and a loss of capacity will result. If not repaired promptly, the rough running pump can cause mechanical damage to itself or other system components.
7. Badly worn piston cups or valves and valve seats will cause a serious drop in pump capacity. This will be indicated by a drop in pressure when guns are turned on. Worn piston cups are very easy to detect because of the water leakage. The piston cup should be replaced just as soon as this leakage is noticed. If it is allowed to continue some of the water may work past the piston rod seals into the pump crankcase. Water in the pump crankcase will cause severe corrosion of the bearings causing rapid wear. Worn valves can be detected only by visual examination of each valve assembly. The most prevalent cause of valve wear is the use of highly abrasive liquids which will cause the valve and valve seat to wire cut. The cut starts as a very small groove but increases very rapidly once the valve starts to leak through this groove. If the valves are replaced as soon as they start to show this cutting action it will prevent the valve seat from becoming cut in a similar manner and keep the cost of replacement parts to a minimum.
8. If a portion of the pump delivery is allowed to bypass because the #1 control valve is not completely closed there may not be adequate flow to develop full pressure. This also will cause rapid wear in the control valve; any excess flow should be bypassed only by the pressure regulator.
9. Pump cylinder bodies must withstand an extreme amount of shock and pulsation while the pump is in operation. If the pump is allowed to freeze, due to not being drained, the freezing may crack the cylinder body walls in almost any location. If the crack should occur on the suction valve or cylinder portion of the body it may allow a small amount of air to enter on the suction stroke and cause noisy operation or a decrease in pumping capacity. If the crack develops in the walls between the cylinder cavities or discharge valve cavity it may allow the water to flow from one cavity to the adjacent cavity and rob the pump of its effective displacement. This will not cause noisy operation but will reduce the pump capacity and may show up as a drop in pressure when the discharge is open.
10. Water may accumulate in the pump crankcase from two sources, the most prevalent being leakage of the cups as explained in paragraph 7. The other means of accumulation is a condensation of moisture inside the crankcase due to changes in weather or the repeated heating and cooling of the pump due to its normal usage. Pumps that are used rather consistently and run for a considerable period of time to heat the oil and other working parts will not normally accumulate water by condensation. If the cups are replaced as soon as it starts to leak it will be impossible for water to enter the crankcase from this cause.
11. Worn connecting link bearings will develop only because of unusual or adverse operating conditions. They will, however, be seriously affected by corrosion if water is present in the crankcase and they will wear out from overheating if the oil is not clean and of good quality. For this reason we recommend thorough draining, cleaning and refilling with new oil at the specified interval and prior to any storage period. Replace link inserts as soon as any wear is noticed to avoid damage to crankshaft journals. Also see paragraph 17 and lubrication instructions.
12. Lack of sufficient oil in crankcase can quickly cause failure of pump power end and result in extensive repairs. Oil level should be checked periodically

during normal operation as well as when maintenance work of any nature is performed. Insufficient oil will first be indicated by excessive heat and should be corrected immediately.

13. A foaming mixture will sometimes have the same effect as a small air leak in the suction line. This is because various quantities of the foam are drawn through the suction line into the pump disrupting the normal flow of water.
14. Pressure regulators may become sluggish in action due to the plunger sticking or fitting too tightly in its cylinder. This condition may be caused by an accumulation of chemicals collecting in and around the plunger, or may be due to excessive corrosion of the plunger parts. To check this condition, remove and clean the plunger. After cleaning the plunger, parts should be covered with a waterproof grease before assembling.

In some cases there is a tendency for the pressure regulator to chatter or vibrate excessively. This is an indication of unstable operation due to nozzling in the high or low capacity range of the regulator; the nozzling requirements should be at least 50% and not exceed 90% of pump capacity.

Due to nozzle wear, the system requirements may exceed the 90% limit, resulting in cycling or hammering of the regulator. This can readily be checked by replacing the worn nozzle.

15. If a large piece of foreign matter becomes lodged between a pump valve and valve seat or if something of this kind becomes wedged in so that it prevents the valve from operating normally we can expect a drastic drop in capacity and considerable surge or pulsation will be noticed in the discharge line. To correct a condition of this kind it is usually necessary to examine each valve in the pump until the offending condition is located. The use of clean liquid and seeing that the suction strainer is in proper condition will prevent trouble of this kind.
16. Noisy pump operation will sometimes be caused by a piston rod being loose in the crosshead. This will become evident only after the rod becomes so extremely loose that some end motion can be found between the rod and crosshead. A noise of this kind usually has a regular cadence timed with each stroke. When this condition occurs it is always necessary to replace both the rod and the crosshead.
17. More than the recommended amount of preload to the crankshaft bearings will reduce bearing life, require more power, and generate more heat. Less than

the recommended preload may cause a knock timed with the crankshaft rotation. Check for loose bolts on the crankshaft end caps or adjust shims to obtain proper bearing preload.

Worn roller bearings will continue to run for a long time but will introduce wear particles into the oil (which can cause other damage), may cause overheating, and may or may not cause a noticeable noise. Check oil regularly; check for wear particles when changing oil.

UNUSUAL CONDITIONS WHICH MAY CAUSE TROUBLE

Pinion shaft breakage on the drive side of the pump may be caused by having the pulley or sprocket positioned too far away from the pump bearing. It may also be caused by a loose drive chain if the pump is chain driven.

If the V-belts have a tendency to wear rapidly, it may be due to having the belt tightener pulley adjusted too far into the belt, throwing a reverse bend in the belt where it passes over the pulley. If very much reverse angle seems necessary to keep the belt tight, other provisions should be made for tightening, such as placing shims under the pump base or otherwise spreading the drive centers enough to take up the belt length. On multiple V-belt drives, a complete set of belts should be installed when making a replacement. Further, all the belts in one set should be checked for length and accurately matched to avoid placing an undue load on any one belt.

F. E. Myers, 1101 Myers Parkway, Ashland, Ohio 44805-1969
419/289-1144, FAX: 419/289-6658, www.femyers.com

Myers (Canada), 269 Trillium Drive, Kitchener, Ontario N2G 4W5
519/748-5470, FAX: 519/748-2553

Pre June 1, 2008

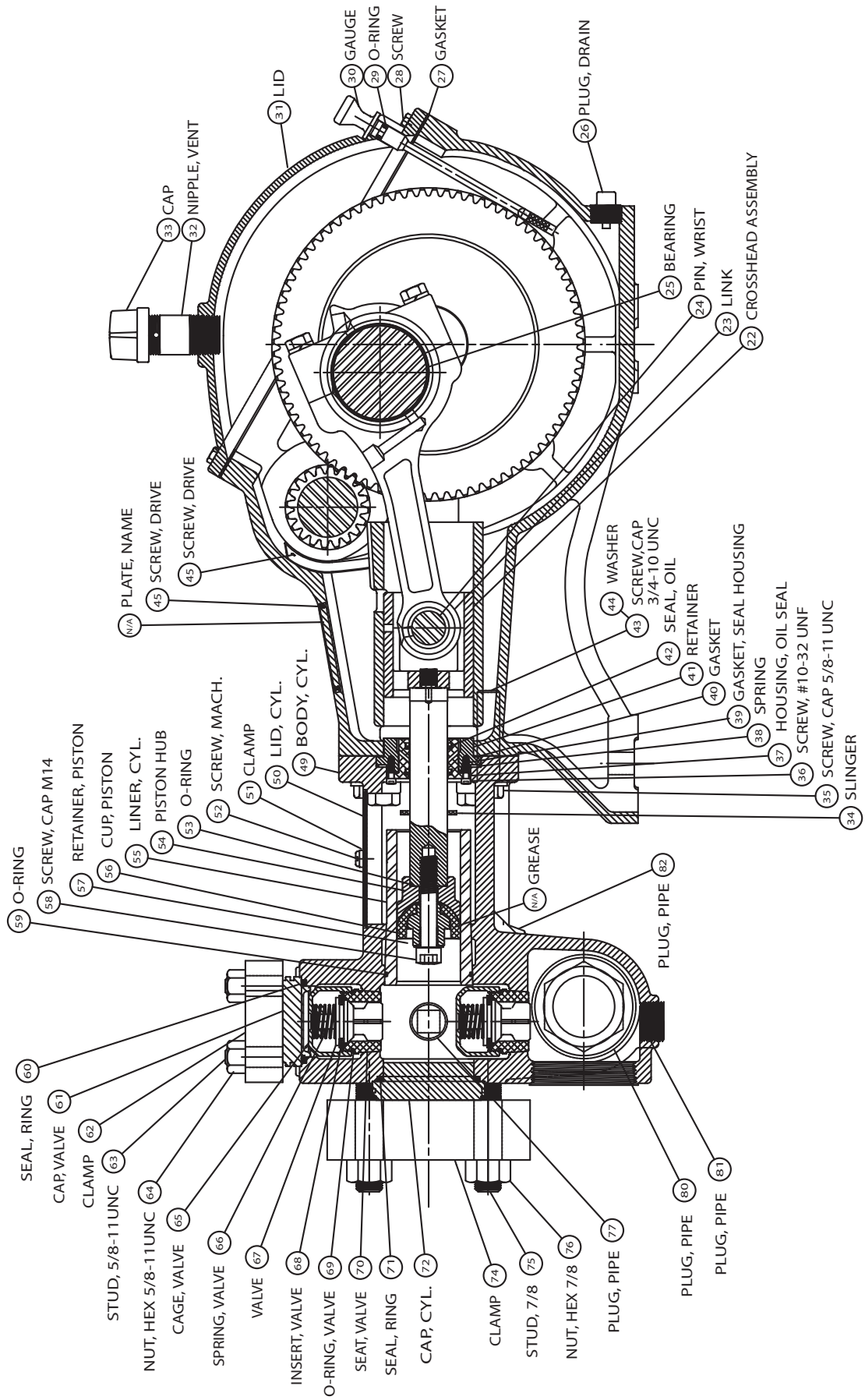

E70-23, E80-20

Post June 2008

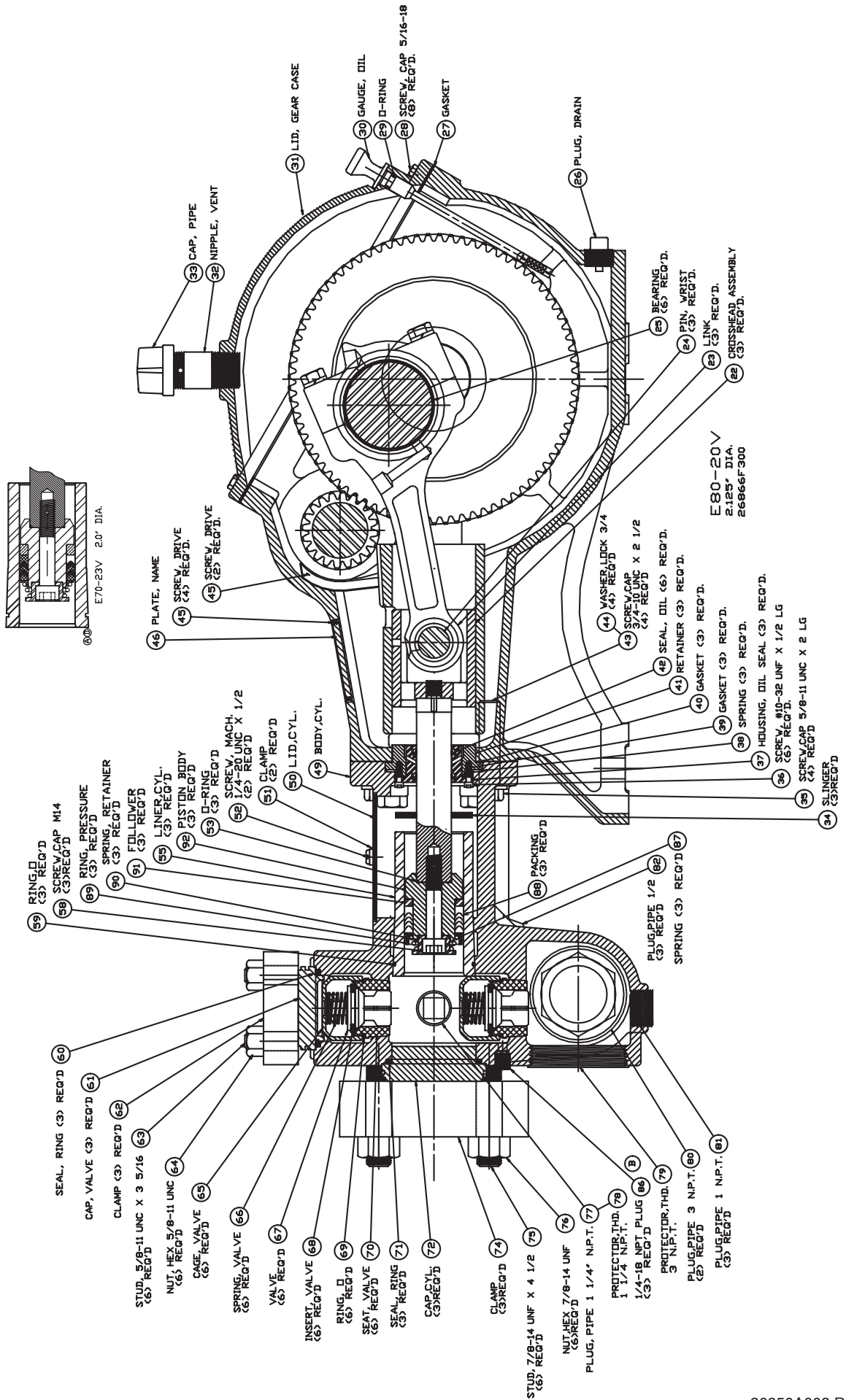

"E" SERIES DRIVE POWER END

(Pinion shaft shown rotated 59° for clarity)

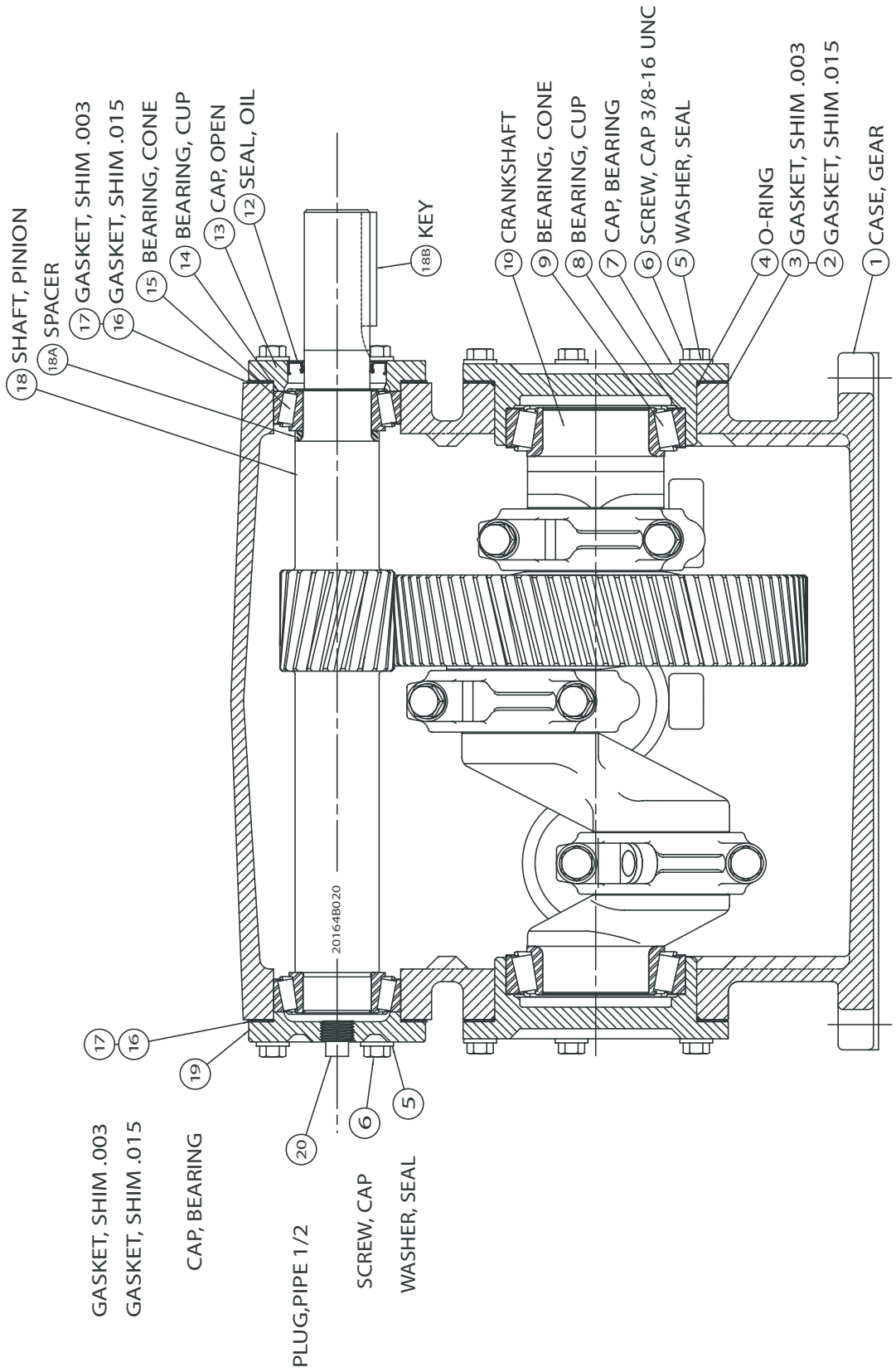

"E" SERIES – SHAFT DRIVE – PARTS LIST

Ref.	Name & Description	Qty.	Part No.	Ref.	Name & Description	Qty.	Part No.
1	Case, gear	1	04625E010E	50	Lid, cylinder (Pony rod cover)	1	M01520A000
2	Shim, plastic, pink, .015"	6	05068A016	51	Clamp, lid	2	26842A000
3	Shim, plastic, green, .003"	6	05068A018	52	Screw, mach. 1/4-20 UNC x 1/2"	2	148850001
4	O-ring, 5-1/8" O.D.	2	05876A098	53	O-ring, 1-1/4" O.D.	3	110-000024-218
5	Washer, seal	18	14946A003	54	Piston hub E54-23	3	7206-0390-00A
6	Screw, cap 3/8"-16 UNC x 1"	18	19101A013		E70-23	3	7206-0393-00A
7	Cap, bearing, crankshaft	2	04624B004		E80-20	3	7206-0396-00A
8	Cup, bearing, crankshaft	2	05675A013		E110-14	3	7206-0358-00A
9	Cone, bearing, crankshaft	2	05674A018	55	Liner, cyl. E54-30 1.750 I.D.	3	26849A000
10	Crankshaft, w/75 teeth gear				E70-23 2.000 I.D.	3	20851A001
	(All E series except E80-25)	1	20355C022		E80-20 2.125 I.D.	3	20851A004
	E80-25	1	20355C044		E110-14 2.500 I.D.	3	M01512A003
11	Key, Sq. 3/8 x 3/8 x 2-1/2	1	05818A048	56	Piston, cup, E54-30 1.750" O.D.	3	7206-0389-00A
12	Oil Seal, 1-5/8"	1	05710A017		E70-23 2.000 O.D.	3	7206-0392-00A
13	Cap, open, pinion	1	04563A001		E80-20 2.125 O.D.	3	7206-0395-00A
14	Cup, bearing, pinion	2	05675A009		Flat Back E110-14 2.500 O.D.	3	7203-0617-00A
15	Cone, bearing, pinion	2	05674A013	57	Retainer, piston E54-30	3	7206-0391-00A
16	Shim, .015" Thk.	4	05231A075		E70-23	3	7206-0394-00A
17	Shim, .003" Thk.	4	05231A074		E80-20	3	7206-0397-00A
18	Shaft, pinion, 19 Teeth	1	20164B020		E110-14	3	7206-0389-00A
18A	Spacer	1	20164B022A	57A	Washer, lock	3	06107A013
19	Cap, closed, bearing, pinion	1	04741B001	58	Screw, cap, .551" M-14 metric	3	16654A006
20	Plug, Pipe, 1/2" NPT, Sq. Hd.	1	05022A039	59	O-ring, 2-15/16" O.D., cyl. liner	3	05876A095
22	Crosshead Assembly			60	Seal, ring, valve cap	3	26862A001
	(All E series except E80-25)	3	06211B042	61	Cap, valve	3	26848A000
	E80-25	3	06211B044	62	Clamp, 5/8" stud, valve cap	3	20848A000
23	Link, with bushing & screws	3	17042C002	63	Stud, 5/8-11 UNC x 3-5/16 Lg.	6	05659A560
	Bushing, wrist pin	3	B01619A000K	64	Nut, hex 5/8"-11 UNC	6	19109A046
	Washer, lock	6	05454A004	65	Cage, valve	6	7203-0544-00B
	Screw, cap	6	19103A016	66	Spring, valve	6	7206-0302-00A
24	Wrist pin	3	M01525A001K	67	Valve, guide	6	7203-0542-00A
25	Bearing, two halves	3	15245A101K	68	Insert, valve, polyurethane	6	7203-0546-00A
26	Plug, drain, magnetic, 3/4-14	1	17481A002	69	O-ring, valve, 2.004 O.D.	6	110-000032-201
27	Gasket, lid, special shape	1	06201C000	70	Seat, valve	6	7203-0543-00B
28	Screw, cap 5/16"-18 x 7/8" St.	8	19100A033	71	Seal, ring, cylinder cap	3	7202-0041-00A
29	O-ring, oil gauge	1	110-000110-201	72	Cap, cylinder	3	26805A000
30	Gauge, oil & O-ring (Item 29)	1	17360A011K	74	Clamp, 7/8" stud, cylinder cap	3	20856A000
31	Lid, gear case	1	04561B000	75	Stud, 7/8"-14 UNF x 4-1/2"	6	05659A089
32	Nipple, special vent	1	17995A000	76	Nut, hex, 7/8-14 UNF	6	19109A072
33	Cap, pipe	1	05737A002	77	Plug, pipe, 1-1/4" NPT	1	05022A041
34	Slinger, neoprene	3	05059A263	80	Plug, pipe, 3" NPT	2	03210A000
35	Screw, cap, hex, 5/8-11 UNC x 2	4	19105A008	81	Plug, pipe, 1" NPT	3	05022A043
36	Screw, skt. hd. 10-32 UNF x 1/2"	6	06106A034	82	Plug, pipe, 1/2" NPT	3	05022A015
37	Housing, oil seal	3	24959A000	87	Spring	3	20853A000
38	Spring, seal retainer	3	M01643A000	88	Packing E70-23V	3	18922A000
39	Gasket, seal housing, 2.312 O.D.	3	05059A434		E80-20V, E80-25	3	18922A004
40	Gasket, Vellumoid, 3.50 O.D.	3	05059A058	89	Pressure Ring E70-23V	3	18921A000
41	Retainer, oil seal housing	3	24958A000		E80-20V, E80-25	3	20854A000
42	Oil Seal, U cup, Viton	6	22835A003	90	Retainer, spring	3	20852A003
43	Screw, skt. hd. 3/4-10UNC x 2-1/2"	4	06106A038	91	Follower E70-23V	3	18932A002
44	Washer, lock, 3/4"	4	05454A003		E80-20V, E80-25	3	20855A000
45	Screw, drive, .133 x 5/16"	6	05160A004	92	Piston body E70-23V	3	18924A004
49	Body, cylinder	1	18639F008		E80-20V, E80-25	3	20850A011

Note: **Bold type** indicates "normal" wear items or items replaced when rebuilding a reciprocating pump.

MYERS LIMITED WARRANTY

F. E. MYERS warrants that its products are free from defects in material and workmanship for a period of twelve (12) months from the date of purchase or eighteen (18) months from the date of manufacture, whichever occurs first.

During the warranty period and subject to the conditions hereinafter set forth, **MYERS**, will repair or replace to the original user or consumer parts which prove defective due to defective materials or workmanship of **MYERS**. Contact the nearest authorized **MYERS** distributor, **MYERS** authorized service center or **MYERS** for warranty service. At all times, **MYERS** shall have and possess the sole right and option to determine whether to repair or replace defective equipment, parts or components.

Start up reports and electrical system schematics may be required to support warranty claims. Warranty is effective only if **MYERS** supplied or authorized control panels are used, where applicable. All dual seal pumps must have seal failure and heat sensors attached, functional and monitored for the warranty to be in effect. If a seal failure should occur, **MYERS** will only cover the lower seal and labor thereof. If the heat sensor and seal fail sensor is not attached and functional, the warranty is void.

LABOR, ETC. COSTS: MYERS shall in NO EVENT be responsible or liable for the cost of field labor, removal and/or reinstallation charges of any **MYERS** product, part or component thereof, or the expense of freight.

THIS WARRANTY WILL NOT APPLY: (a) to defects or malfunctions resulting from failure to properly install, operate or maintain the unit in accordance with printed instructions provided; (b) to failures resulting from abuse, accident or negligence; (c) to normal maintenance services and the parts used in connection with such service; (d) to units which are not installed in accordance with applicable local codes, ordinances and good trade practices; or (e) if the unit is moved from its original installation location; (f) unit is used for purposes other than for what it was designed and manufactured; (g) to any unit which has been repaired or altered by anyone other than **MYERS**, a **MYERS** distributor or a **MYERS** authorized service center and (h) to any unit which has been repaired using non factory specified parts/OEM parts.

RETURN OR REPLACED COMPONENTS: any item to be replaced under this Warranty must be returned to **MYERS** in Ashland, Ohio, or such other place as **MYERS** may designate, freight prepaid.

PRODUCT IMPROVEMENTS: MYERS reserves the right to change or improve its products or any portions thereof without being obligated to provide such a change or improvement for units sold and/or shipped prior to such a change or improvement.

WARRANTY EXCLUSIONS: MYERS MAKES NO EXPRESS OR IMPLIED WARRANTIES WHICH EXTEND BEYOND THE DESCRIPTION ON THE FACE HEREOF. **MYERS** SPECIFICALLY DISCLAIMS THE IMPLIED WARRANTIES OF MERCHANTABILITY AND FITNESS FOR ANY PARTICULAR PURPOSE.

Some states do not permit some or all of the above warranty limitations and, therefore, such limitations may not apply to you. No warranties or representations at any time made by any representatives of **Myers** shall vary or expand the provision hereof.

LIABILITY LIMITATION: IN NO EVENT SHALL MYERS BE LIABLE OR RESPONSIBLE FOR CONSEQUENTIAL, INCIDENTAL OR SPECIAL DAMAGES RESULTING FROM OR RELATED IN ANY MANNER TO ANY **MYERS** PRODUCT OR PARTS THEREOF. PERSONAL INJURY AND/OR PROPERTY DAMAGE MAY RESULT FROM IMPROPER INSTALLATION. **MYERS** DISCLAIMS ALL LIABILITY, INCLUDING LIABILITY UNDER THIS WARRANTY. FOR PROPER INSTALLATION **MYERS** RECOMMENDS INSTALLATION BY PROFESSIONALS.

Some states do not allow the exclusion or limitation of incidental or consequential damages, so the above limitation or exclusion may not apply to you.

This Warranty gives you specific legal rights and you may also have other rights which vary from state to state.

In the absence of suitable proof of this purchase date, the effective date of this warranty will be based upon the date of manufacture.

Direct all notices, etc. to:

Service Department, F.E. MYERS, A Pentair Company, 1101 Myers Parkway, Ashland, Ohio 44805.



Myers[®]
INDUSTRIAL PRODUCTS

1101 Myers Parkway, Ashland, Ohio 44805-1969
419/289-1144 • FAX 419/289-6658 • TLX: 948-7443

START-UP REPORT

Distributor _____ Order #: _____

Installing Contractor: _____ Phone: _____

Sales Contact: _____ Phone: _____

Customer & Location _____

1. SYSTEM INFORMATION

- A. Size of wet well: _____ Manufacturer: _____
- B. Discharge from bottom of basin: _____ Location: _____
- C. Inlet from bottom of basin: _____ Location: _____
- D. Type of check valves: _____
- E. Type of piping _____
- F. Does system have suction and discharge gauges? _____
- G. Pressure reading? Suction _____ Discharge _____
- H. Liquid being pumped: _____ Temperature: _____ % of solid: _____
- I. Sketch or photograph of system attached? _____
- J. Any additional comments on system: _____

2. ELECTRICAL INFORMATION

- A. Control panel part #: _____ Panel rated amps: _____
Manufacturer _____ Voltage: _____ Phase: _____
- B. Heater size: _____
- C. Location of panel to wet well: _____
- D. Incoming line voltage: _____ Actual? _____
- E. Voltage to pumps _____ Actual? _____
- F. Type of junction box: _____ Manufacturer: _____
- G. Are floats installed in wet well? _____
- H. Are floats set to engineer's spec? _____
- I. Are floats wired for proper sequencing? _____
- J. Any additional comments on electrical: _____

3. PUMP INFORMATION

- A. Type of pump: _____ Serial # _____
- B. Voltage: _____ Phase: _____ RPM: _____ Amps: _____
- C. Impeller size: _____ C.O.S. TDH: _____ GPM: _____
- D. Voltage supplied from panel: _____ Actual?: _____
- E. Actual amperage (all phases): _____ amps _____ amps _____ amps
- F. Have you checked pump rotation? _____
- G. Any additional comments on pumps: _____

Acknowledge that all information is accurate and proper procedures have been followed:

Customer Signature: _____ Date _____

Start-up Technician: _____ Date _____

Send to: Warranty Department, 740 E. Ninth Street, Ashland, OH 44805, Fax: 419-207-3344,
or e-mail to: startupreport@myers.com

We will make this a permanent part of our file on this order.